



Over 50 Years of Differential Pressure Flow Metering Experience...

ORIPAC MODEL 4150-T

PTFE (Teflon®) Construction for Metering Water, Air, Corrosive Fluids and High-Temperature Gases

ABOUT THE ORIPAC MODEL 4150-T

The ORIPAC is a complete orifice plate flow metering package. It incorporates a stainless steel orifice plate with a unique holder or carrier ring containing metering taps and integral gaskets.

Unlike a standard orifice plate, the ORIPAC is a true primary element including the various components for differential pressure measurement. It was designed for use wherever there is an application for a conventional flow orifice plate. It can also be used in place of other primary differential producers for efficiency and cost effectiveness. The ORIPAC was designed and developed by leading authorities in the differential flow measurement field.

- Unitized PTFE (Teflon®) construction
- Over 30 proven years field service
- Available for specific pressure and temperature requirements

• About the Oripac Model 4150-T	This page
• Features and Benefits	Page 2
• Dimension Sheet	Page 3
• Head Loss and Accuracy.....	Page 4
• Flow Capacity Chart.....	Page 5 - 6
• Part No. Reference System	Page 7
• Specification Sheet.....	Page 8
• Installation Sheet.....	Page 9

Standard size units available from stock and customized units are available to meet specific field requirements including flange rating, pipe schedule and differential pressure. Installation is accomplished simply by slipping the self-centering Oripac between standard 150# flanges (orifice flanges are not required).

The ORIPAC is available for most line sizes and meets or exceeds AMSE, AGA and ISO standards.



MODEL 4150-T - Material: All Teflon®



ORIPAC MODEL 4150-T

Model 4150-T Features & Benefits

Unitized PTFE (Teflon®) construction. Simplifies installation - lower installed costs than traditional orifice mounting.

Integrated metering taps properly located and predrilled. Use w/standard ANSI flanges - orifice flange unions eliminated. No drilling/tapping pipe.

Full faced integral gasket pre-attached. Precludes potential alignment problems during installation.

Self-centering within standard flanges. Oripac O.D. sits snug within bolt circle of specified flange rating insuring concentricity - centering devices or additional components eliminated.

"Corner" type metering taps. Established coefficient accuracy values.

PTFE (Teflon®) construction. Use or superior high-tech materials eliminating rusting and plugging of sensing ports. Remarkable chemical resistance.

Custom Manufacture (to specific temp & pressure requirements). Standard configurations available from stock, custom units available in different materials, thickness and configuration to meet specific requirements for harsh applications.

Proven through a wide and varied range of applications and installations since 1984. Over 30 year history of reliability and accuracy.

Sized for specific pipe schedules or special inside pipe diameters including US/Metric, etc. Insures accuracy by eliminating pipe inside diameter to Oripac inside diameter mismatches.

Any bore size to produce any specific differential pressure. Ability to match range on an existing d/p transmitter or indicating gage without recalibration or replacement.

Orifice bore calculated to match specified "headloss" requirements. Exact differential pressure values and overall system head loss can be calculated and pre-determined.

Orifice bore styles available include Concentric, Eccentric, Segmental, Quadrant edge, multiple bore. Able to address challenging flow applications including: low viscosity fluids, gasses containing liquids, limited pipe runs, etc.

Bi-directional flow capabilities. Orifice plate available without bevel to accommodate flow in both directions.

Drain hole at bottom or vent hole at top available for orifice plate. Additional tap can be installed for drainage purposes. Orifices may require a drain at bottom of orifice to allow passage of condensate. Air in liquid lines may require a vent hole at top of orifice.

Orifice plate thickness option. Thickness of orifice plate provided according to ASME/AGA specs standard. Special plate thicknesses available to address high pressure lines, thick bore "critical flow" requirements, etc.

Any flange material or rating (125/150#, 250/300#, 600#, 900#, 1500#, 2500#) DIN Ratings or custom flange requirements. Eliminate potential flange rating mismatches, no need for additional centering devices - ideal for use within lightweight duct flanges.

Ideal for light weight duct measurement. Mounts between thin angle or plate flanges for lightweight installation.

Can be used within cast iron standard flanges. (Orifice flanges not available in cast iron). Simple orifice device now available for cast iron piping without welding.

Can be sized for restriction or pressure drop control in conjunction with flow measurement. Eliminate additional throttling valve by combining flow meter and restrictor as one integral unit.

Port size (Pizometer through hole) can be increased if required – Reducing the chance of plugging in lines containing particulates, solids, etc.

Metering Taps drilled "straight through" to the pipe I.D. Easily accessible: clean using pipe cleaner or rod out kit.

Can be used with Lambda flange mount bracket for installing instrumentation. Option for direct mount installation of manifold transmitter or indicating gage offering consolidated installation (Remote mount available)

Pre-attached nameplate. Serial #, Tag #, ID, Bore and other information available. Also available: SS attachment w/SS wire or w/RTJ type nameplate holder.

Flexible readout options. Can be used with any Transmitter, Gage, Manifold arrangement.

Standard valve kit available. Includes nipples and shutoff valves to streamline installation.



Toll-Free: 1-800-587-5423 · Tel: (631) 587-1000 · Fax: (631) 587-1011
71 Deer Park Avenue · Babylon, NY 11702-2801 USA
www.LambdaSquare.com · email: info@LambdaSquare.com

ORIPAC MODEL 4150-T

Model 4150-T Dimension Sheet

SPECIFICATIONS:

- Weight: Varies with line size. (See chart)
- Pressure: Up to 150# Flange Rating
- Temperature: 200° F to +400° F (dependant on material and gasketing)
- Head Loss: Similar to standard orifice plates. (See ref. sheet TM-100 or refer to tech support sheet attached)
- Fluids: Most liquids, gases. High temperature, corrosive, etc.
- Line Sizes: 1/4" to 24" standard. Specials to 60". Custom fabrications available.
- Installation: Standard ANSI flange, 150# (orifice flanges not required)
- Accuracy: 0.6% of full scale flow. (Refer to tech support sheet)
- Pipe Requirements: Refer to installation sheet or TM120. General requirements 10 Dia up and 5 Dia down
- Bore: Concentric standard, eccentric, quadrant edge, segmental, multi bore available. Drain or vent hole available on concentric bores



MODEL 4150-T - PTFE (Teflon®)
Construction for Gas and Liquids

Thickness = 1.25" (including gaskets)

DIMENSIONS IN INCHES

On all line sizes

Line Size (D)	Oripac Outside Diameter (OD)	Pipe Inside Diameter (PID)	Tap Location (CD)	Weight (Pounds)
0.25"	1.890"	0.364"	4.5	1
0.50"	1.890"	0.622"	4.5	1
0.75"	2.250"	0.824"	4.5	1
1.00"	2.625"	1.049"	4.5	1
1.25"	3.000"	1.380"	4.5	1
1.50"	3.375"	1.610"	4.5	1
2.00"	4.125"	2.067"	4.5	2
2.50"	4.875"	2.469"	4.5	2
3.00"	5.375"	3.068"	4.5	3
4.00"	6.875"	4.026"	4.5	3
5.00"	7.750"	5.047"	4.5	4
6.00"	8.750"	6.065"	4.5	5
8.00"	11.000"	7.981"	4.5	6
10.0"	13.375"	10.020"	4.5	8
12.0"	16.125"	12.000"	4.5	10
14.0"	17.750"	14.000"	4.5	12
16.0"	20.250"	16.000"	4.5	14
18.0"	21.625"	18.000"	4.5	16
20.0"	23.875"	20.000"	4.5	20
24.0"	28.250"	24.000"	4.5	22

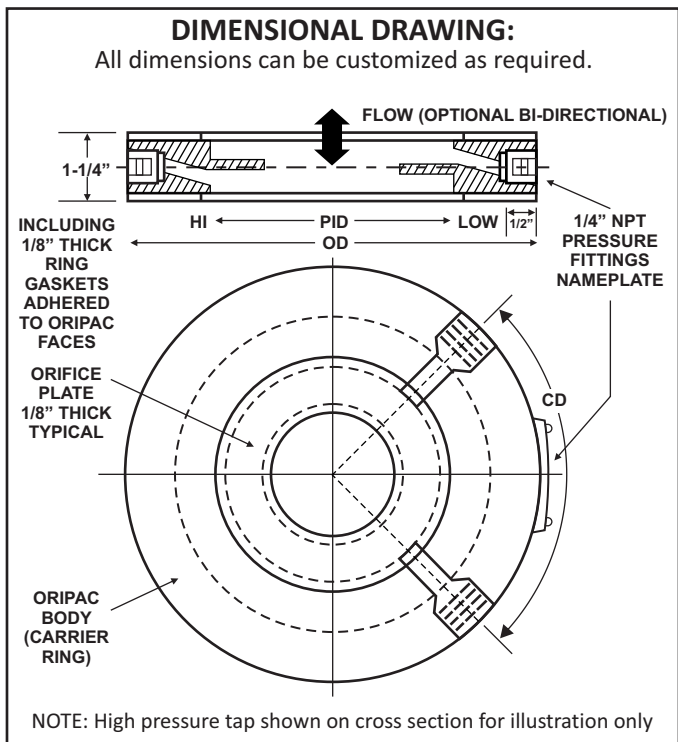

Toll-Free: 1-800-587-5423 · Tel: (631) 587-1000 · Fax: (631) 587-1011
71 Deer Park Avenue · Babylon, NY 11702-2801 USA
www.LambdaSquare.com · email: info@LambdaSquare.com

ORIPAC MODEL 4150-T

Model 4150-T Head Loss and Accuracy

The importance of proper pressure tap connections for orifice plate installations is often minimized or overlooked in the field. Faulty connections nullify the precision of the machining in the manufacture of the orifice plate and calibration accuracy of the secondary instrument. An ORIPAC, properly installed, will provide satisfactory, low-cost service over a wide capacity range.

Lambda Square, Inc. has developed the ORIPAC to combine accuracy of measurement with certainty of correct installation. The many advantages in their installation and operation clearly indicate the superiority of the ORIPAC for the majority of conditions under which an orifice installation is suitable.

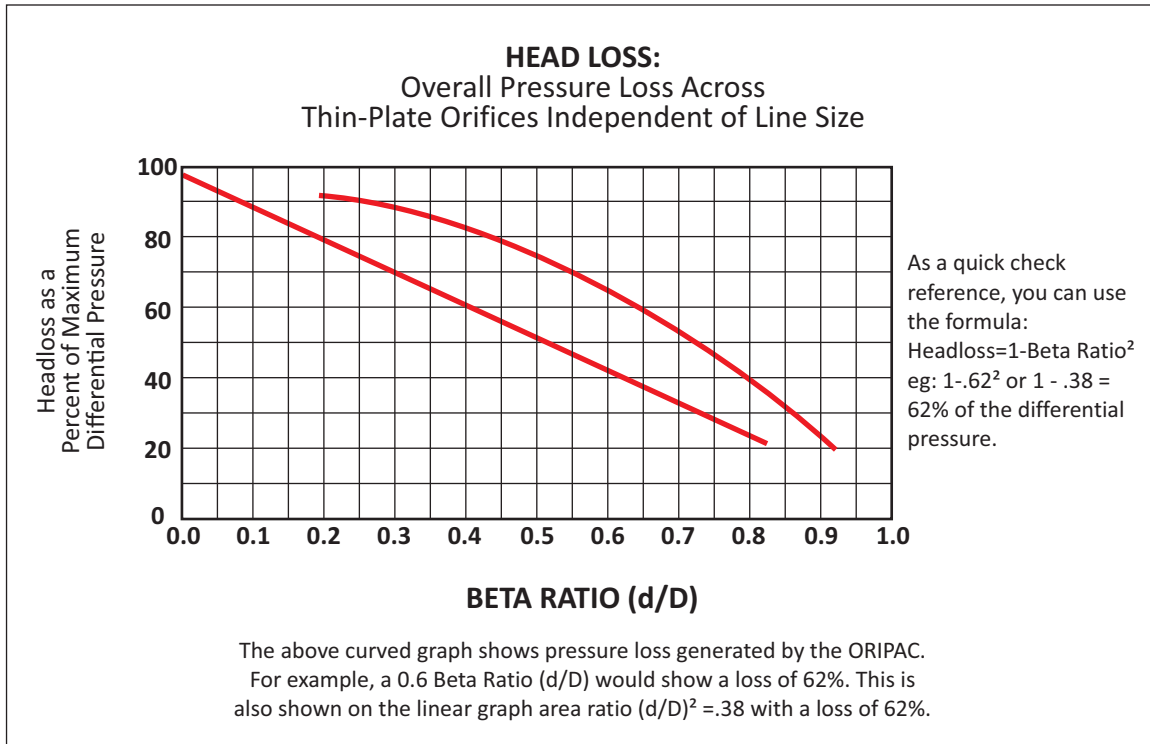

MODEL 4150-T ACCURACY

The ORIPAC utilizes the corner tap proportions as defined in ISO 5167. The ASME Fluid Meters Research Committee has suggested that the dimensionless coefficient equation developed by the International Standards Organization (ISO) and presented in ISO 5167 is significantly better for the broad spectrum of flow measurement applications throughout process industries.

The coefficient values used in the ORIPAC bore calculations represent the same confidence level assigned to the flange and radius taps widely accepted in fluid flow measurement.

The accuracy assigned to the coefficient values is ± 0.6% full scale flow for d/D (Beta) values 0.2 to 0.6 and ± β% for Beta values 0.6 to 0.75 (i.e. β of 0.7 would have an uncertainty value of ± 0.7% full scale flow).

Accuracy of the differential signal produced by the ORIPAC equals or exceeds that of a properly manufactured and installed flange or radius tap orifice meter.



Toll-Free: 1-800-587-5423 · Tel: (631) 587-1000 · Fax: (631) 587-1011
71 Deer Park Avenue · Babylon, NY 11702-2801 USA
www.LambdaSquare.com · email: info@LambdaSquare.com

ORIPAC MODEL 4150-T

Model 4150-T Air Flow Capacity Chart

Based on 70° F, 14.7 PSIA
(Base Conditions)

LINE SIZE	QTY	BORE	BETA	LAMBDA MODEL #	INCHES d/p W/C	Air Flow in SCFM		
						14.7 PSIA (0 PSIG)	20 PSIA (5.30 PSIG)	100 PSIA (85.30 PSIG)
1/2"	10	0.200"	0.32	4150-P-0.5-0.200	20	2.4	3.6	6.6
1/2"	10	0.310"	0.50	4150-P-0.5-0.310	100	12.2	19.6	36.4
1/2"	10	0.430"	0.69	4150-P-0.5-0.430	200	32.8	56.2	107.5
3/4"	10	0.250"	0.30	4150-P-0.75-0.250	20	3.7	5.7	10.3
3/4"	10	0.400"	0.49	4150-P-0.75-0.400	100	20.2	32.4	60.3
3/4"	10	0.580"	0.70	4150-P-0.75-0.580	200	59.9	102.9	197.2
1"	10	0.300"	0.29	4150-P-01-0.300	20	5.2	8.1	14.8
1"	10	0.520"	0.49	4150-P-01-0.520	100	34.2	54.9	102.1
1"	10	0.720"	0.69	4150-P-01-0.720	200	91.3	156.5	300.0
1.25"	8	0.400"	0.29	4150-P-1.25-0.400	20	9.3	14.4	26.3
1.25"	8	0.700"	0.51	4150-P-1.25-0.700	100	62.1	99.8	185.5
1.25"	8	1.00"	0.72	4150-P-1.25-1.00	200	180.0	310.0	595.2
1.5"	10	0.500"	0.31	4150-P-1.50-0.500	20	14.6	22.6	41.2
1.5"	10	0.800"	0.50	4150-P-1.50-0.800	100	80.8	129.9	241.5
1.5"	10	1.100"	0.68	4150-P-1.50-1.100	200	212.2	363.9	697.4
2"	15	0.600"	0.29	4150-P-02-0.600	20	20.9	32.4	59.1
2"	15	1.000"	0.48	4150-P-02-1.00	100	125.7	202.0	375.8
2"	15	1.450"	0.70	4150-P-02-1.45	200	372.1	639.9	1,227.6
2.5"	8	0.750"	0.30	4150-P-2.5-0.750	20	32.7	50.6	92.5
2.5"	8	1.250"	0.50	4150-P-2.5-1.250	100	197.5	317.6	590.9
2.5"	8	1.750"	0.70	4150-P-2.5-1.750	200	544.0	936.6	1,798.9
3"	10	0.920"	0.30	4150-P-03-0.920	20	49.2	76.1	139.1
3"	10	1.500"	0.49	4150-P-03-1.500	100	282.9	454.8	846.2
3"	10	2.150"	0.70	4150-P-03-2.150	200	816.7	1,405.0	2,696.3
4"	10	1.200"	0.30	4150-P-04-1.200	20	83.6	129.4	236.5
4"	10	2.000"	0.50	4150-P-04-2.000	100	503.8	810.1	1,507.6
4"	10	2.800"	0.70	4150-P-04-2.800	200	1,380.0	2,373.0	4,553.7
5"	8	1.500"	0.30	4150-P-05-1.500	20	130.5	202.1	369.3
5"	8	2.500"	0.50	4150-P-05-2.500	100	786.2	1,264.4	2,353.5
5"	8	3.500"	0.69	4150-P-05-3.500	200	2,152.8	3,701.6	7,103.2
6"	10	1.800"	0.30	4150-P-06-1.800	20	187.9	291.0	531.8
6"	10	3.000"	0.49	4150-P-06-3.000	100	1,331.6	1,820.1	3,387.9
6"	10	4.200"	0.69	4150-P-06-4.200	200	3,097.2	5,325.2	10,219.3
8"	5	2.400"	0.30	4150-P-08-2.400	20	333.9	517.3	945.3
8"	5	4.000"	0.50	4150-P-08-4.000	100	2,015.0	3,241.5	6,034.9
8"	5	5.600"	0.70	4150-P-08-5.600	200	5,532.0	9,525.4	18,290.0
10"	5	3.000"	0.30	4150-P-10-3.000	20	521.6	808.0	1,476.8
10"	5	5.000"	0.50	4150-P-10-5.000	100	3,145.5	5,060.4	9,421.7
10"	5	7.000"	0.70	4150-P-10-7.000	200	8,626.4	14,846.8	28,506.2
12"	0	3.600"	0.30	4150-P-12-3.600	20	750.9	1,163.4	2,126.5
12"	0	6.000"	0.50	4150-P-12-6.000	100	4,530.0	7,288.2	13,570.3
12"	0	8.400"	0.70	4150-P-12-8.400	200	12,430.0	21,397.0	41,089.0
14"	0	4.000"	0.30	4150-P-14-4.000	20	927.1	1,436.6	2,625.8
14"	0	6.600"	0.50	4150-P-14-6.600	100	5,477.7	8,812.9	16,409.4
14"	0	9.300"	0.70	4150-P-14-9.300	200	15,251.5	26,262.7	50,427.8
16"	0	4.500"	0.30	4150-P-16-4.500	20	1,172.6	1,817.1	3,321.3
16"	0	7.600"	0.50	4150-P-16-7.600	100	7,264.6	11,688.3	21,764.1
16"	0	10.700"	0.70	4150-P-16-10.700	200	20,179.9	34,749.3	66,737.6
18"	0	5.200"	0.30	4150-P-18-5.200	20	1,565.8	2,426.3	4,435.1
18"	0	8.600"	0.50	4150-P-18-8.600	100	9,302.1	14,966.9	27,869.9
18"	0	12.000"	0.70	4150-P-18-12.000	200	25,299.9	43,535.3	83,587.0
20"	0	5.780"	0.30	4150-P-20-5.780	20	1,935.4	2,999.1	5,482.2
20"	0	9.600"	0.50	4150-P-20-9.600	100	11,588.2	18,645.7	34,720.8
20"	0	13.500"	0.70	4150-P-20-13.500	200	32,115.3	55,303.3	106,215.9
24"	0	7.000"	0.30	4150-P-24-7.000	20	2,838.1	4,398.3	8,040.0
24"	0	11.700"	0.50	4150-P-24-11.700	100	17,229.6	27,726.3	51,633.8
24"	0	16.300"	0.70	4150-P-24-16.300	200	46,810.5	80,610.2	154,823.8



LAMBDA SQUARE, INC.

Toll-Free: 1-800-587-5423 · Tel: (631) 587-1000 · Fax: (631) 587-1011
71 Deer Park Avenue · Babylon, NY 11702-2801 USA
www.LambdaSquare.com · email: info@LambdaSquare.com

ORIPAC MODEL 4150-T

Model 4150-T Water Flow Capacity Guide

Based on 70°F Flowing Temperature
Beta Based on Standard Schedule Pipe I.D.

Line Size	Bore	Beta	Lambda Model Number	Inches d/p W/C	Flow in GPM
1/2"	0.200"	0.32	5300-0.5-0.200	20	0.62
1/2"	0.310"	0.50	5300-0.5-0.310	100	3.44
1/2"	0.430"	0.69	5300-0.5-0.430	320	13.00
3/4"	0.250"	0.30	5300-0.75-0.250	20	0.97
3/4"	0.400"	0.49	5300-0.75-0.400	100	5.69
3/4"	0.580"	0.70	5300-0.75-0.580	320	23.82
1"	0.300"	0.29	5300-01-0.300	20	1.38
1"	0.520"	0.49	5300-01-0.520	100	9.63
1"	0.720"	0.69	5300-01-0.720	320	36.15
1.25"	0.400"	0.29	5300-1.25-0.400	20	2.46
1.25"	0.700"	0.51	5300-1.25-0.700	100	17.48
1.25"	1.00"	0.72	5300-1.25-1.00	320	71.77
1.5"	0.500"	0.31	5300-1.50-0.500	20	3.85
1.5"	0.800"	0.50	5300-1.50-0.800	100	22.73
1.5"	1.100"	0.68	5300-1.50-1.100	320	83.95
2"	0.600"	0.29	5300-02-0.600	20	5.52
2"	1.000"	0.48	5300-02-1.00	100	35.34
2"	1.450"	0.70	5300-02-1.45	320	147.74
2.5"	0.750"	0.30	5300-2.5-0.750	20	8.63
2.5"	1.250"	0.50	5300-2.5-1.250	100	55.54
2.5"	1.750"	0.70	5300-2.5-1.750	320	216.30
3"	0.920"	0.30	5300-03-0.920	20	12.97
3"	1.500"	0.49	5300-03-1.500	100	79.94
3"	2.150"	0.70	5300-03-2.150	320	324.16
4"	1.200"	0.30	5300-04-1.200	20	22.03
4"	2.000"	0.50	5300-04-2.000	100	141.51
4"	2.800"	0.70	5300-04-2.800	320	547.11
5"	1.500"	0.30	5300-05-1.500	20	34.39
5"	2.500"	0.50	5300-05-2.500	100	220.80
5"	3.500"	0.69	5300-05-3.500	320	853.09

Line Size	Bore	Beta	Lambda Model Number	Inches d/p W/C	Flow in GPM
6"	1.800"	0.30	5300-06-1.800	20	44.40
6"	3.000"	0.49	5300-06-3.000	100	317.74
6"	4.200"	0.69	5300-06-4.200	320	1,226.98
8"	2.400"	0.30	5300-08-2.400	20	87.95
8"	4.000"	0.50	5300-08-4.000	100	565.77
8"	5.600"	0.70	5300-08-5.600	320	2,195.86
10"	3.000"	0.30	5300-10-3.000	20	137.35
10"	5.000"	0.50	5300-10-5.000	100	883.04
10"	7.000"	0.70	5300-10-7.000	320	3,421.26
12"	3.600"	0.30	5300-12-3.600	20	197.73
12"	6.000"	0.50	5300-12-6.000	100	1,271.62
12"	8.400"	0.70	5300-12-8.400	320	4,930.86
14"	4.000"	0.30	5300-14-4.000	20	244.14
14"	6.600"	0.50	5300-14-6.600	100	1,537.49
14"	9.300"	0.70	5300-14-9.300	320	6,052.57
16"	4.500"	0.30	5300-16-4.500	20	308.76
16"	7.600"	0.50	5300-16-7.600	100	2,038.95
16"	10.700"	0.70	5300-16-10.700	320	8,007.74
18"	5.200"	0.30	5300-18-5.200	20	412.26
18"	8.600"	0.50	5300-18-8.600	100	2,610.71
18"	12.000"	0.70	5300-18-12.000	320	10,027.37
20"	5.780"	0.30	5300-20-5.780	20	509.55
20"	9.600"	0.50	5300-20-9.600	100	3,252.22
20"	13.500"	0.70	5300-20-13.500	320	12,742.82
24"	7.000"	0.30	5300-24-7.000	20	747.18
24"	11.700"	0.50	5300-24-11.700	100	4,835.93
24"	16.300"	0.70	5300-24-16.300	320	18,572.50



Toll-Free: 1-800-587-5423 · Tel: (631) 587-1000 · Fax: (631) 587-1011
71 Deer Park Avenue · Babylon, NY 11702-2801 USA
www.LambdaSquare.com · email: info@LambdaSquare.com

ORIPAC MODEL 4150-T

Part No. Reference System

Typical part number for an 2" 150# rating s/40 Oripac Model 4150-T with a 0.600" Bore

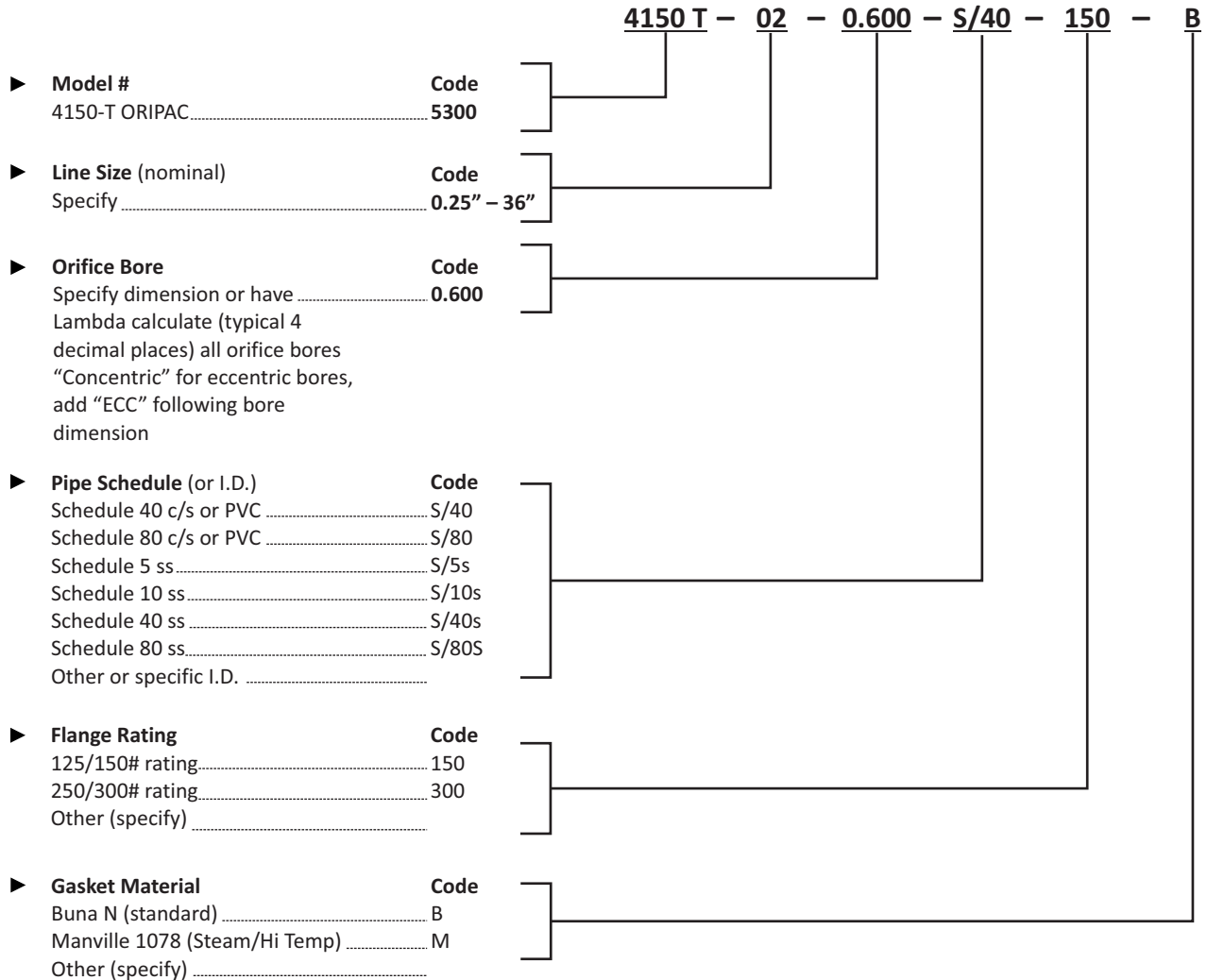

▶ **Metering Taps**
 1/4" FNPT taps standard.

▶ **Optional Extension Nipples/Shut off Valves (Connection Kits):**
 316 SS or PVC 1/4" Diameter s/40 nipple with 316 SS or PVC 1/4" FNPT x 1/4" FNPT shut off valve reduced port ball standard (Specify connection kit as separate line item)

Notes: A "CUS" following part # indicates custom configuration to be detailed and confirmed by factory prior to ordering. Examples include: CPVC or Teflon® material, drain or vent holes, special bores (eccentric, quadrant edge, segmental) bi-directional flow, etc.



Toll-Free: 1-800-587-5423 · Tel: (631) 587-1000 · Fax: (631) 587-1011
 71 Deer Park Avenue · Babylon, NY 11702-2801 USA
www.LambdaSquare.com · email: info@LambdaSquare.com

ORIPAC MODEL 4150-T

Model 4150-T Specification Sheet

SUGGESTED SPECIFICATIONS:

GENERAL: This specification describes a differential pressure type of metering primary for the main line metering of liquid, gas or steam in a _____" pipe. The orifice plate flow meter "Oripac Model 4150-T" wafer type unit shall include high & low metering taps utilizing a "corner tap" configuration. Orifice primary shall meet or exceed ASME requirements for corner style metering taps with regards to accuracy, tolerances & calculations. A flow vs differential pressure curve shall be provided for each set of flow conditions.

MOUNTING: The orifice metering primary shall be suitable for installation between standard ANSI flanges (any rating/material) mounted on standard pipe (any material). The unit shall be "self centering" within the bolt circle of the flanges. No alignment of the orifice shall be necessary. Drilling and or tapping of the main or flanges will not be allowed or required. The overall laying length shall be 1.25" including pre-attached ring type 1/8" thick Buna "N" Gaskets. Other gasket materials available upon request.

CAPACITY: Normal flow rate of ____SCFM or ____ PPH or ____GPM at a differential pressure to be determined by Lambda Square Inc. at pressures & temperatures provided by engineer and calculated by Lambda Square Inc.

MATERIALS OF CONSTRUCTION: The Oripac Model 4150-T primary element shall be monolithic (single piece) constructed entirely of PVC. Metering connections shall be 1/8" or 1/4" NPT female taps. Hose barb connections or extension nipples may be threaded to high & low pressure connections if desired.

ACCURACY: The orifice primary shall be precision calculated, bored and bench calibrated to ASME & ISO specifications yielding a predictable accuracy of +/- 0.6 % of full scale flow. Calculations shall be performed by Lambda Square Inc. to determine exact differential & headloss at full scale & normal flow conditions

Accuracy must be substantiated by flow calibration data obtained on metering the same flow elements. Flow calibration data must replicate line size, comparable flow range and Reynolds #. Certified calibration must have been performed in at least three physically independent and recognized flow calibration facilities. Calculation formulas shall be based on ASME guidelines. The orifice primary shall be tested under similar conditions for at least 10 years and shall be equal in all respects to ORIPAC Model 4150-T as manufactured by Lambda Square Inc. of Babylon, NY.

METER PERFORMANCE: Calculations for pressure loss may be performed in conjunction with the Oripac flow calculations by Lambda Square Inc. The overall pressure loss and differential pressure shall be determined at maximum & normal flow conditions. The permanent headloss shall be within the requirements of the application, and determined by the engineer in conjunction with Lambda Square Inc.



LAMBDA SQUARE, INC.

Toll-Free: 1-800-587-5423 · Tel: (631) 587-1000 · Fax: (631) 587-1011
71 Deer Park Avenue · Babylon, NY 11702-2801 USA
www.LambdaSquare.com · email: info@LambdaSquare.com

ORIPAC MODEL 4150-T

Model 4150-T Installation Instructions

General: Many of the installation problems associated with standard orifice plates have been eliminated by the use of the Oripac. Simply follow these instructions for an accurate and reliable meter.

Pipe Requirements: Upstream and downstream pipe requirements are contingent upon two factors: (a) Beta Ratio:-ratio of the orifice bore "b" divided by the inlet bore (pipe I.D.) (b) The type of fitting or disturbance upstream of the Oripac. For most applications, 10 pipe dia. upstream & 5 dia. downstream are sufficient. (5 pipe dia. up and 2 dia. down are acceptable for non-critical application.) Refer to additional piping requirement chart below for specific scenarios.

Installation Tips: (a) If possible, do not install a valve upstream if it is going to be throttled. Install on the downstream a minimum of 6 diameters from the Oripac. (b) The use of straightening vanes is not necessary for most applications.

Optional Connection Kit:
Includes 1/4" S.S. or PVC Extension Nipples with 1/4" S.S. or PVC Port Ball Valves - FNPT Ends.



Actual Installation: (a) Insert bolts through bottom half of the flange bolt circle. (b) Slide Oripac between flanges (make sure arrow on Oripac faces in the direction of flow) (c) Make sure pressure connections are properly positioned. Oripac can be installed vertically or horizontally. For horizontal liquid lines, install the Oripac with the connections on or under the horizontal center line. For horizontal air or gas lines, install with the connections on or above the horizontal center line. They should also be correctly oriented so as to not be blocked by bolts when remainder of bolts are inserted: (d) Add rest of bolts and nuts leaving all bolts loose so Oripac is free to move. (e) If necessary, the Oripac can be centered using a steel ruler to measure the total side to side movement and set Oripac at half way point all around. (f) Lubricate & tighten bolts diametrically alternating to recommend flange torque. (g) Check to insure the Oripac is installed with the arrow facing in the same direction as flow.

Upstream / Downstream Straight Pipe Requirements for the Oripac

Up-Stream Obstruction	Beta Ratio	Upstream Straight Pipe Diameters	Downstream Straight Pipe Diameters
• Single 90° Elbow	0.3	6 D	2 D
• "Tee" or "Y" Fitting	0.5	7 D	3 D
• Tank or Separator	0.7	13 D	4 D
• Globe Valve	0.3	12 D - 24 D	3 D
• Stop Check Valve	0.5	14 D - 16 D	4 D
• Multiple fittings in different planes	0.7	16 D - 24 D	4 D
• Regulator	0.3	20 D	3 D
• Partially open gate valves	0.5	27 D	4 D
	0.7	38 D	4 D

Source: ASME Fluid Meters Sixth Edition 1971 Fig 11-11-1

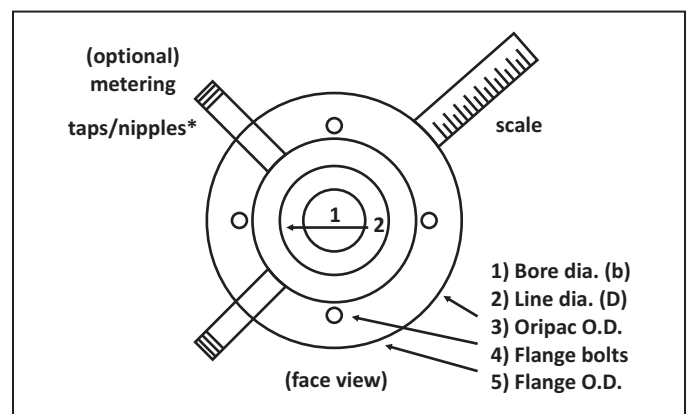
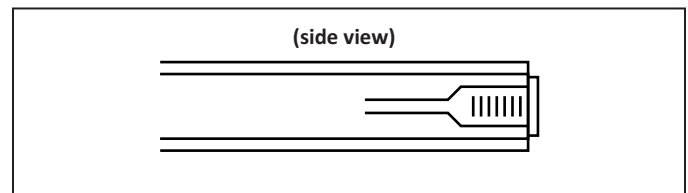

**Bolts should be 1.25" longer than standard
make up flange bolts to accommodate ORIPAC thickness.*