

THREE VALVE MANIFOLD

DOUBLE FLANGED - MODEL 301 / 302

Model 301 three-valve manifold, double flanged manifolds allows the pressure transmitter to be directly mounted, eliminating the need for additional piping, valves and fittings.

FEATURES

- Pressures up to 6,000 psi.
- Standard 2.13" center to center inlet / outlet.
- 3/16" bore.
- Wide choice of materials and options.



Model 302 has the addition of two drain / vent plugs.

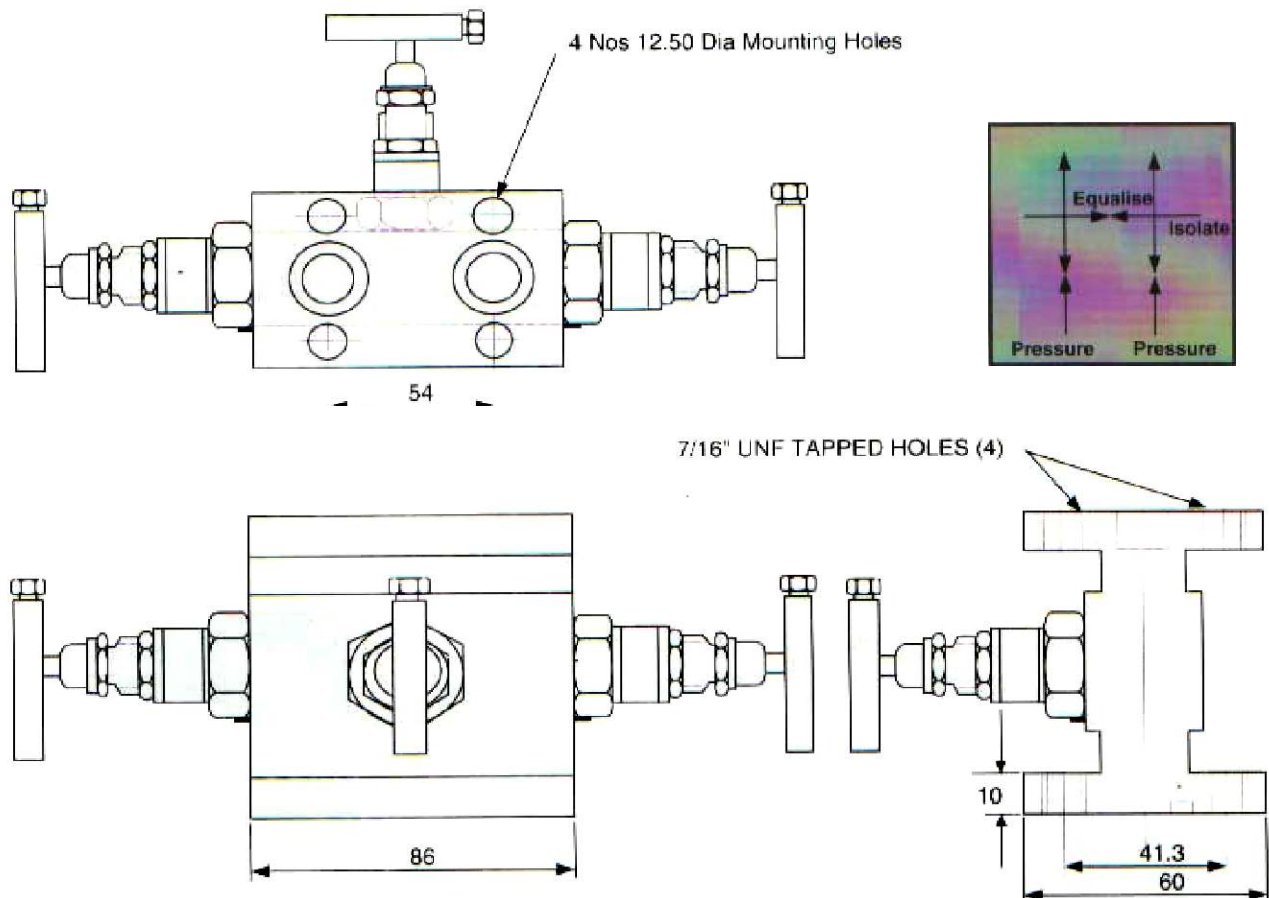

LAMBDA SQUARE

www.lambdasquare.com · email: info@lambdasquare.com

Differential Pressure Flow Measurement Equipment

Over 40 Years of Flow Metering Experience — Consulting Services Available.

1-800-587-5423 · Tel: (631) 587-1000 · Fax: (631) 587-1011

Lambda Square, Inc · 71 Deer Park Avenue · Babylon, NY 11702-2801 USA